

contrast **NEO 1:5**

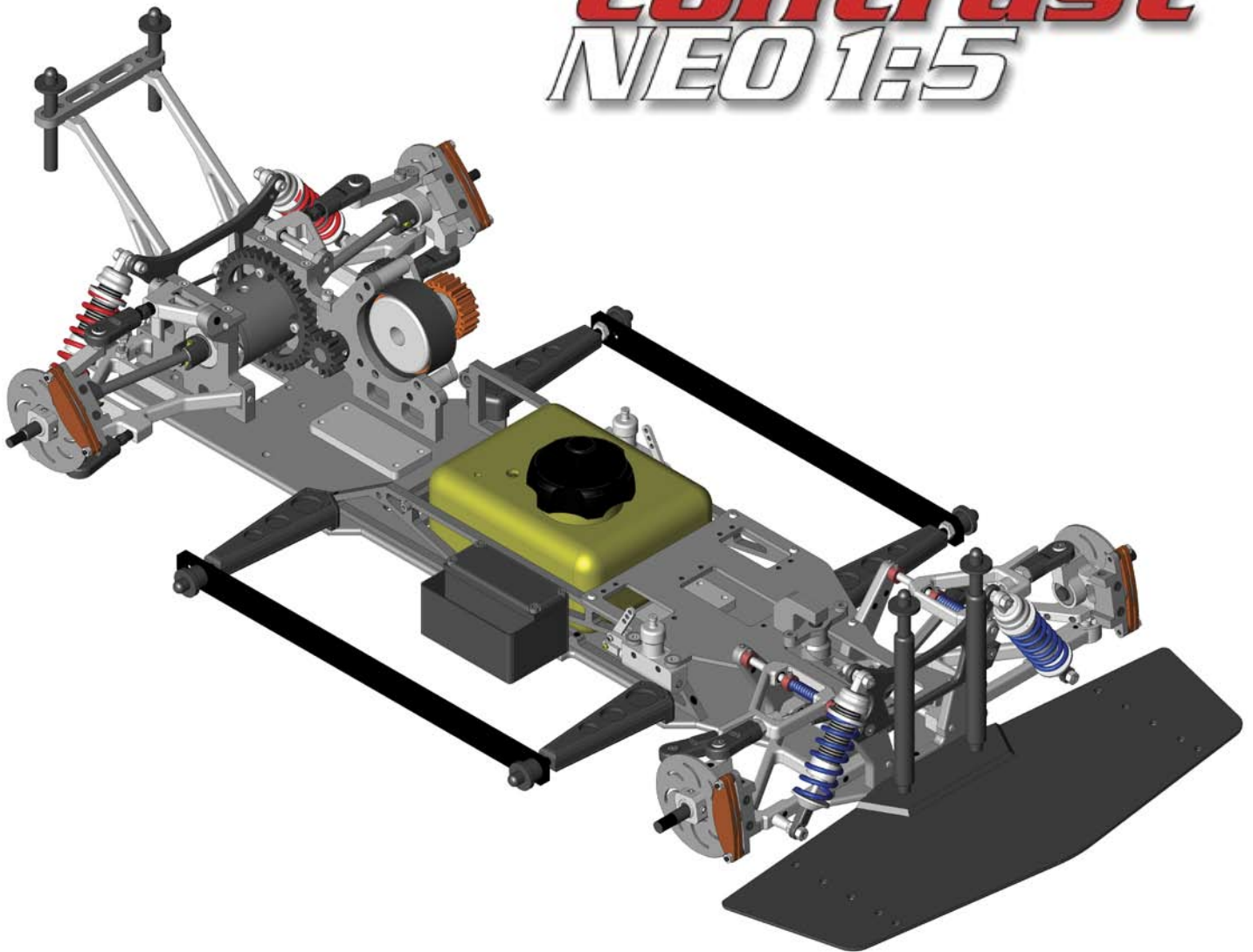

INSTRUCTIONS AND ASSEMBLY HANDBOOK

v1.2 (November 2005)



INTRODUCTION

Esteemed friend, thank you for your purchase of the CONTRAST NEO 1:5. This product that you are going to assemble is the result of many years of testing, study and development by a large team of highly qualified people. The aim of CONTRAST NEO's project is to offer you a high competition car of scale 1:5 with more features and possibilities than the rest of the existing models and brands. But we also wanted to create a simple car, easy to assemble and dismantle, resistant to bumps and to wear and tear, with a high quality manufacturing and besides... it had to be light.

I believe we have achieved that complex aim with the car you have in your hands, and because of this we hope that you enjoy assembling your CONTRAST NEO and get excited about pushing it to the limit on the track.

CONTRAST is an open-minded brand and we wish to know our customer's opinions, as well as the proposals, criticisms, complaints and everything you want to communicate to us, without forgetting the ideas you may have to make the car evolve. You can get into touch with us either by the postal address below or through the specific section you will find in our web site:

www.contrast-racing.com

Now you are part of the CONTRAST team
Yours sincerely

Daniel Fuertes

CONTRAST RACING S.L.

C/ Vila de Lloret, 100
17300 Blanes (Girona) Spain
info@contrast-racing.com



You will find more information and news about Contrast products on our web site:

www.contrast-racing.com

WARNINGS:

- Before starting the assembly read carefully the first pages of this handbook.
- Follow this handbook's instructions through the assembly to get a proper assembly and a perfect adjustment of all the pieces.
- Keep this handbook after the assembly as it may be a help at any moment.
- Contrast Neo has been designed to be used on smooth asphalt surfaces. Any use out of these conditions may cause breaking or premature wear and tear of its mechanical pieces.
- Use original spares and replace worn pieces by the same reference number from the Contrast listing. The use of other brands may cause bad behaviour of the vehicle or even a breakdown.
- Contrast Racing S.L. does not take any responsibility for the use that may be given to this product.
- No section of this handbook can be reproduced without a previous consent.
- Due to the continuous evolution of our products, it is possible that any image or explanation of this handbook does not coincide exactly with the real pieces they refer to.

REQUIRED EQUIPMENT

For the right working of the Contrast Neo you will need the following additional equipment, not included in the kit:



Two or three channel transmitter with batteries, receiver and frequency.



Two or three standard or big size 1:5 servos



Battery pack for the radio, system and servos' working



Unleaded petrol mixed with oil

NECESSARY TOOLS



Allen tools 1.5, 2, 2.5, 3, 4 y 5



plane tools 5.5, 7, 8, 10, 13, 17



Screwdriver, philips type



Screwdriver plane



cut pliers



Tip pliers



Clips pliers



Cutter



Scissors



Calibre



Plastic hammer



grease and oils



Soft screwlock



Medium screwlock



Alcohol or cleaners

THE SET-UP

Contrast Neo is a car meant for competition, although because of its easiness of driving and its mechanical simplicity it's also very suitable for learner drivers or those who have no intention to compete.

Because of its "racing" concept, the Contrast Neo has numerous adjustment possibilities. Next we will explain some guidelines which will make the Contrast Neo's fine tuning easy on any track and situation.

TYRES

- This is one of the most important concepts in the 1:5 modality. The Contrast Neo is able to use any brand of tyres and even a combination of different brands in the rear and front axle.
- Due to its low weight, it is advisable to use tyres that are a bit softer than usual because with hard tyres, it may take too long to get the adequate utilization temperature.
- Softer tyres also allow faster speeds on bends and higher traction power when accelerating.
- Faster speeds as well as longer life of the tyres will be achieved with softer tyres and a smoother drive as well as gas.
- The ideal working temperature of a tyre is between 60° and 80°C.

BALLAST

- The Contrast Neo, once assembled and "ready to go", weighs 9'6 kilos, way below the minimum weight allowed in competition, 10 kg. This allows it to incorporate a mobile ballast system by means of three lodgings placed in three key points of the chassis.
- Putting the biggest weight in the rear lodging placed under the differential, we put the gravity centre behind and add more weight on the rear axle. This raises this axle's road holding increasing traction and stability on slippery tracks or really cold days. In good road holding situations, this rear weight will take away agility from the car, which will become very easy to drive but slow and sluggish.
- The central position, placed under the engine, is the best choice in normal conditions and tracks with a good grip, because it offers a good commitment between steering easiness and stability in the rear axle.
- The ballast's forward position, placed opposite the tank, is meant for situations of high temperature and much road holding of the track. This position adds more weight on the front axle, creating a very fast and agile car, taking away road holding to the rear axle without reaching damage traction capacity.
- With the three types of ballast we offer you (one of them included in the kit) you can make combinations which will allow you to create intermediate adjustments among the three positions previously mentioned.

CHASSIS

- Contrast Neo's chassis has got four possible points of connexion with the engine to use it as reinforcement, gaining a chassis rigidity up to 100%.
- These four points are placed in the following way:
Point 1.- Side chassis left joined to the engine's left support by means of the optional kit, ref 150017
Point 2.- Side chassis right joined to the engine's lid by means of the pieces of the optional kit, ref 150017
Point 3.- Rear right mount joined to the engine's lid back section
Point 4.- Rear left mount joined to the engine's left support.
- Of all these points, point 4 must always be strongly joined because it guarantees the needed distances and free movement among the transmission gear.
- Points 1, 2 and 3 can be joined at will to increase chassis rigidity, which will be particularly beneficial in high grip tracks.
- The order of joining of these points must be the following:
Point 4 alone (middle chassis) a good solution for the majority of situations and as a starting point.
Point 4 + point 3 (rigid chassis) the intermediate step for tracks with a higher grip. The chassis keeps a little amount of flexion in its central area.
Point 4 + point 3+ points 1 and 2 (very rigid chassis) Just for cases of extreme road holding on the track. A rigidity of the 100% is gained. Points 1 and 2 must always be joined together. It is not advisable to join just one of them.
- You must take into account that the more rigid the chassis, the more important it is that there is a good adjustment of the suspension in order to get the most of the car.

SUSPENSION GEOMETRY

- Together with tyres and ballast, the wheel suspension geometry is the third group of adjustments to take into account for getting the optimum behaviour from the Contrast Neo. We will order them from the most to the least important: rear toe in, front Caster, front toe out, rear camber and front camber.
- Rear toe in regulates a great part of the rear axle's stability. The more toe in the more rear grip. In the Contrast Neo this adjustment is related as well to the ballast position. The amount of toe in recommended in each tyre is from 2,5° to 3° in high grasp conditions and from 3° to 4° in slippery tracks and/or cold days.
- Front caster regulates the amount of tyre surface that touches the ground when front wheels are turned, so it controls the grasp of front axle when it turns. The bigger caster's angle there is less area of rubber in contact with the track and therefore the car turns less. Otherwise, a small angle of caster creates a very nervous and sensitive steering which can destabilize rear axle. This adjustment depends much on the track's grasp, rear axle's stability and tyres used in rear axle. The more stable the car's rear axle is, the small angle of caster we can use, improving the steering agility and speed on a bend. It is advisable to begin tests with a big angle of caster, and then decreasing it progressively as we need more steering. To use different adjustments of caster in the right side and in the left one can be advisable at certain tracks to adapt the answer of the car's steering to the different bend's radius.
- Contrary to the back wheels, the 1:5's front wheels require a certain toe out to create a stable and easy to drive car, with this toe out we get a docile steering at a high speed and we make driving easy in fast bends at the same time we improve the entry in slow bends. An excess of toe out means a big braking in a straight and it increases the front tyres wear and tear. The right adjustment is between 1.5° and 3° in each front wheel.
- The camber's adjustments, as the front one as the rear one, aim to give the needed inclination to the wheel for the most possible tyre's area to be in contact with the ground inside a whole bend and with all existent inclinations and flexions. In the front axle, caster uses to be 0° with the possibility of using 0,5°, positives or negatives depending on the agility we are looking for in the front axle. In the rear axle caster is a bit more important, overall because it also affects to the car's traction capacity. Depending on the track and the atmosphere temperature, the rear caster's adjustments vary between -1° and -2,5°.

SUSPENSIONS AND ANTI-ROLL BARS

- Contrast Neo's low weight also affects to the damper spring and oils, because it allows using softer adjustments which improve traction and grasp in low road-holding conditions.
- In Contrast's options catalogue there are different springs and silicon oils with progressive hardness which will allow you to adjust the hardness of the suspensions according to your preferences, and in this handbook's "SET UPS" sections we propose to you the combinations sequences used by our best official drivers.
- Our damper springs have been specially designed to wheel with the car at a very short distance from the ground (between 8 and 10 mm), keeping a soft answer during the first 4 millimetres of run, increasing endurance quickly during the following 4 mm of run to avoid the car touches the ground without the need for using bumpers or suspension limiters.
- Always use Contrast high quality silicone oils for the suspensions. Low quality oil loses density quickly when its temperature is increased by the work made and it makes the car's behaviour really worse.
- Remember that a suspension's hydraulics is always related to a certain tension of spring, therefore if you make a drastic change of hardness on springs, you will have to vary the hydraulics' density as well.
- Anti-roll bars are a basic element in car's final behaviour. Car's traction capacity, agility in slow bends and easiness of driving at high speed depend to a large extent on them.
- Generally, Contrast Neo needs a hard or very hard anti-roll bar at the front combined with a medium or hard anti-roll bar at the back.
- With a soft front anti-roll bar the car will take much inclination in bends, and it will increase front wheel's adherence. This can be beneficial in certain tracks since front axle's agility increases in a considerable way but in return we may also lose stability in the rear axle inside fast bends and lose traction capacity because of the car's excessive inclination.
- If we soften the rear anti-roll bar we will slightly improve the car's traction and rear axle's grasp, but it will also have more unexpected reactions and we will notice that the car is very soft and with easiness to bow.
- Hardening the front bar the car will become easier to drive in fast areas and it will improve its tracts in a significant way although when entering in slow bend we may suffer some of understeer.
- Hardening the rear bar (harder as bigger adherence the track has) we'll lose some of that axle's general grasp but it will improve easiness of driving due to have more predictable reactions. It may be that traction capacity will decrease a bit, but it will be solved by the biggest track's road holding.

ENGINE AND CARBURETOR ADJUSTMENT

- Now we propose you a basic adjustment system as a starting point, and after that another system to adjust it in a more detailed and suitable way for competition.
- With the engine turned off, close to the maximum the low screw (L) and from that point open it a whole round more about thirty minutes, approximately 1 turn plus 1/2 turn.
- Do exactly the same thing with the high screw (H) and open it a whole round more about thirty-five minutes.
- Start the engine and then give it some soft gas blows when it has been stabilized, adjust the idle screw.
- This adjustment will allow you to start to wheel with a very good performance. Then and with the engine still warm you will must finish to refine it doing some movements in the carburetor's screw (L, H and idle) in steps of five minutes and controlling carburetion looking at the colours of the spark plug's inside.
- In a big scale Zenoah engine, the colour taken by the spark plug's central electrode's ceramic indicates us the adjustment at high r.p.m. whereas the colour of the metallic ring which covers it and where the spark plug is screwed in shows us adjustment at low r.p.m. In this way when you observe the spark plug after wheeling some turns we'll know exactly how the engine is carbureting all its range of revolutions.
- Central ceramic is able to show a range of colours from bright black or wet one with coal dust grains which means very greasy, to a dry and matt greyish white, which means dangerously short. The desirable colours are:
 - A matt and plain black (without coal dust) lightly cleared up which shows a tight but greasy adjustment, ideal for training and little important qualifying rounds.
 - A white coffee-like brown which shows an ideal high carburetion. The engine won't miss us and will yield end to end as many minutes as we wish. Ideal for a final or sub final with hot weather.
 - A dark white or beige colour. The engine is giving all its potential very near its limit. If the atmosphere rises up in temperature it might stay short. Ideal for important classificatory heats lasting ten minutes or finals with cold weather.
- If instead of a beige colour the ceramic becomes greyish or dirty white, take immediately a screwdriver and open the hi adjust an eighth of a round or a bit more (between five and ten minutes if it were a clock) since the engine is warning you it's going to heat up excessively any minute now.
- The metallic ring, which indicates low r.p.m. adjustment, can show itself.
 - Wet black with much coal dust, which indicates us a adjustment too greasy in low r.p.m..
 - Bright black without coal dust or with just a little in some area of the ring; it shows us an ideal low adjustment. It will keep the engine greased allowing us to adjust high adjust to the maximum.
 - Matt black without coal dust and clearing up, it indicates us the engine goes a bit short low adjust; if we refine it very much hi adjust we are going to have problems in a few rounds.
 - Dry dark brown or the ring's metallic colour. Engine excessively dry, temperature problems and strange reactions or too lively at low r.p.m.
- For these readings of the spark plug to be totally truthful avoid the car to be too much time to idle before turning it off since the spark plug colours might vary.
- Use competition high quality oil for the mixture, like Contrast oil which has been specially developed for the conditions and high performance features of the tuned engines.
- The high revolutions per minute Zenoah engine reaches require the use of oil which resists more than 20000 rpm without faint. The use of non-adequate oils, although being from renamed branches, may increase in a considerable way the wear and tear of the piston, the cylinder, of the seals and of the crankshaft bearings.
- Work with amount of oil will between 2,5% and 3,5%. This diminish the engine's temperature and will improve the sealed between the piston and cylinder.
- Use petrol mixed with oil recently. A mixture stored for some weeks may lose its lubricant properties or vary the % of mixture.
- Zenoah engine requires some running when it's used for the first time, at least during the first half an hour of working. This means a soft and careful driving with a little greasy carburetion.
- Watch over the state of the exhaust's inside. A dirty exhaust with an excess of dust coal can make the engine's answer worse.
- Watch over the state of the air filter. A dirty filter with an excess of dust coal can be very dangerous for the engine life.
- For the maintenance and revision of the engine, consult the Zenoah instructions handbook indications included in the kit.

BRAKES

Now we expose you some tips which can be very useful to get a races braking, powerful and secure:

- The most difficult and important of brakes is to find a good relationship between the front one and the rear one. To balance the two axle's brakes, start with a ratio of approximate 60% at the front and 40% at the rear, testing it stopped with your hands. Brake with strength at the track while you start to trace a bend, if the car goes straight, slaken the front brake or tighten the rear one, if the car tends to cross, slaken the rear one or tighten the front one. If the car follows its line entering the bend with the brake pressed, you have gained the suitable balance. Once the brake is balanced, the total brake power is regulated from the radio transmitter, limiting or extending the servo's movement.
- With much brake at the front and little at the rear front wheels are blocked, the car slips, it brakes a bit and it doesn't turn. When braking in a bend having the wheels turned, the car goes straight recovering again its trace sharply when stopping braking.
- With little brakes at the front and much at the rear, when braking the car crosses skidding from the back it becomes impossible to control and it will end up doing a 180 degree turn.
- With balanced brakes, braking is stable, powerful and the car keeps its trace even inside a bend.
- Avoid always the blocking of the wheels, a blocked wheel due to braking excess brakes less.
- Braking power depends mostly on the front tyre's adherence. A soft tyre offers a powerful braking, whereas a hard tyre is blocked up easily giving as a result a longer and more imprecise braking.
- From this we know that the brakes must be adjusted with the tyres being hot after wheeling a few rounds. If they are adjusted in cold, when wheels are warming a braking excess or an unbalance front/rear may appear.
- Most of braking power is got thanks to rear brake. For a race braking the rear brake must be adjusted the most powerful possible without reaching to neither loose adherence nor stability. The more grasp the track has got, the more amount of rear brake we'll be able to apply. Although we can almost reach a front/rear 50/50% proportion just in exceptional grasp tracks.
- Revise periodically discs and shoes. The important thing about discs is that they must be perfectly flat since discs that are slightly bent make braking very irregular which is blocked very easily. Las pastillas must be flat as well without excessive tear marks and without crystallizing. It's a good idea to sandpaper them periodically with very fine sandpaper put on a table for them to stay plain again and to eliminate rubber and grease remains. Meanwhile a little shower with Contrast cleaner spray fro time to time will maintain them clean of rubber and dust.

The logo for Contrast features a stylized red 'C' with a white outline, positioned above the word 'contrast' in a bold, italicized, red sans-serif font. The word 'contrast' has a white outline and a slight shadow effect, giving it a three-dimensional appearance. The entire logo is set against a white background within a red-bordered frame.

contrast

ASSEMBLY HANDBOOK

CONSIDERATIONS TO TAKE INTO ACCOUNT

- 1) To apply screwlock of soft hardness to all the screws and nuts without autolock is recommended for avoiding breakdowns and disadjustments.
- 2) The screws which fix the transmission gears must be secured with medium hardness screwlock.

STEP 1 SUSPENSION FRONT AXLE

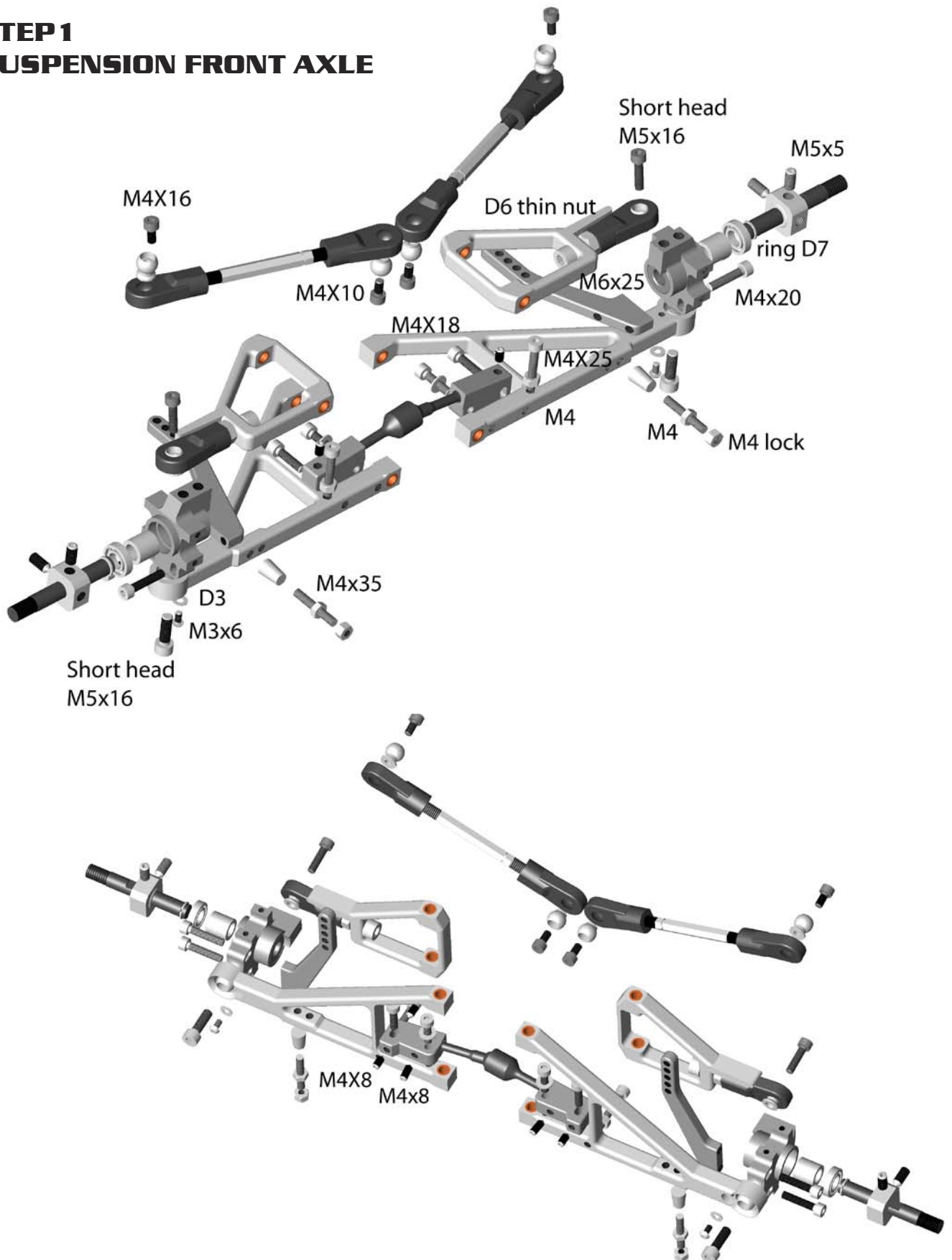

STEP 2 CHASSIS AND SUPORTS

The radio plate must be fixed with 8 screws
M4x10 round head

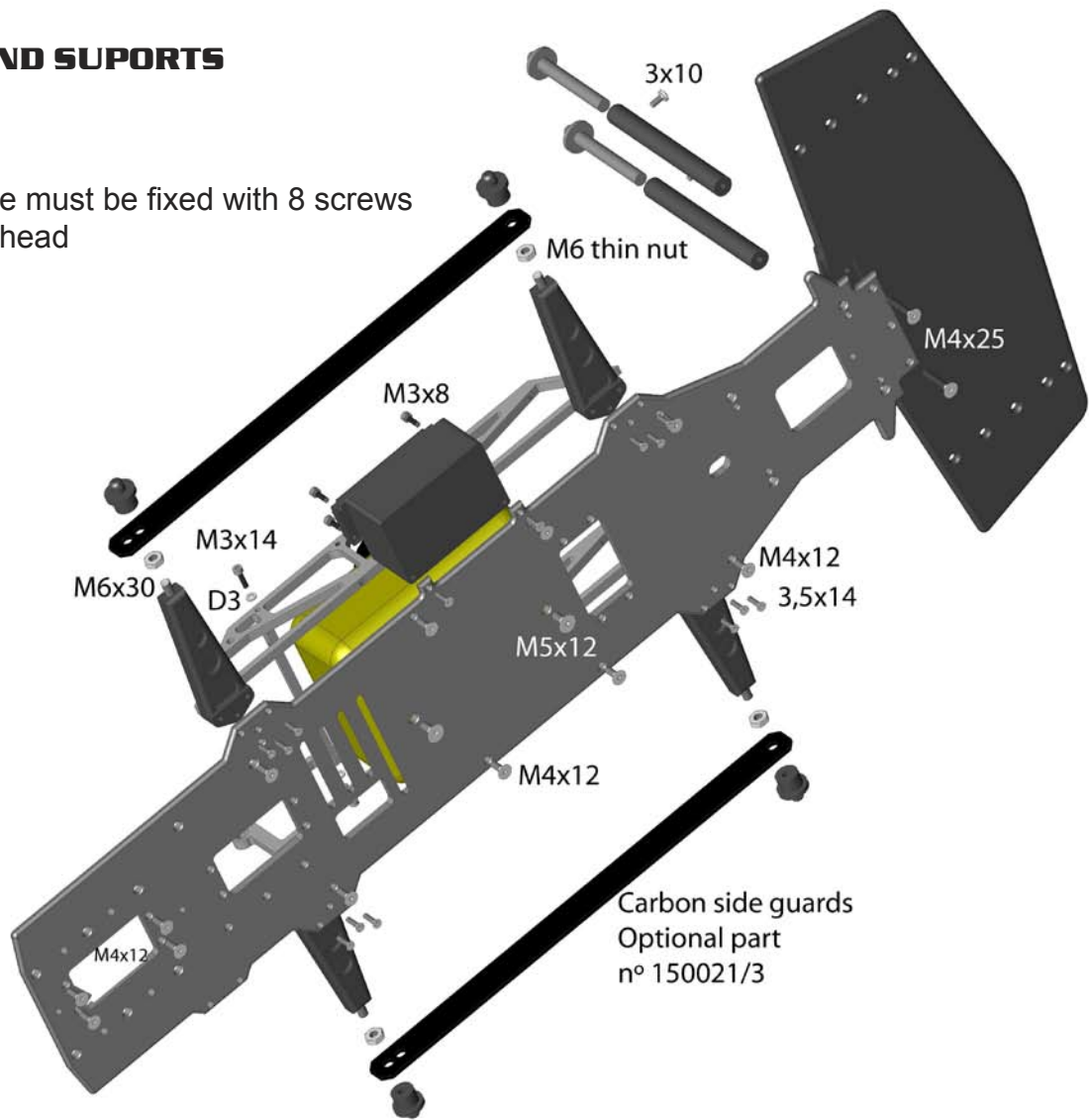

STEP 3 SERVO SAVER AND STEERING SYSTEM

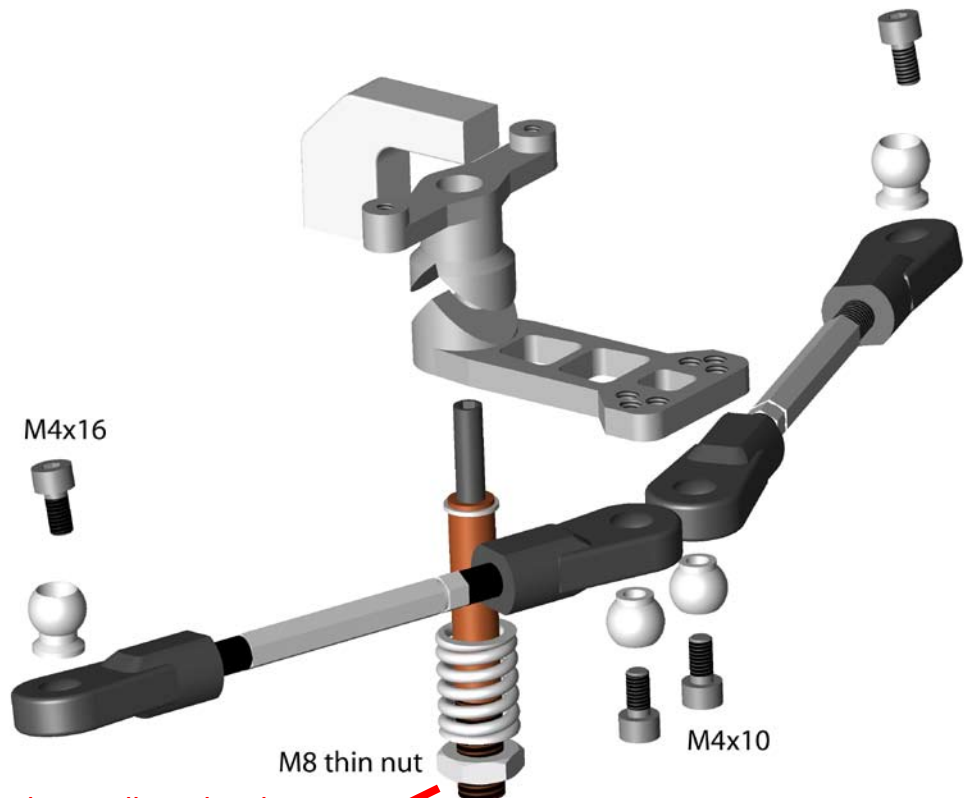

VERY IMPORTANT! Apply medium hardness screwlock or a second nut to fix the sprig.

STEP 4
FRONT AXLE TO CHASSIS

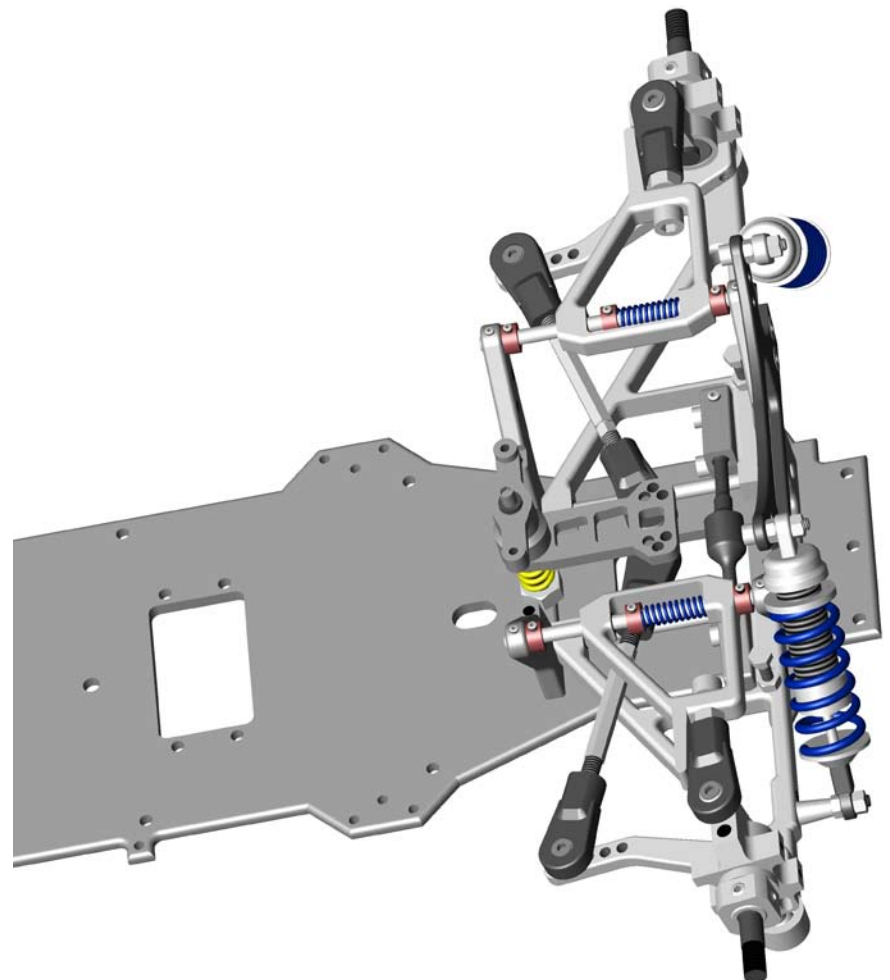
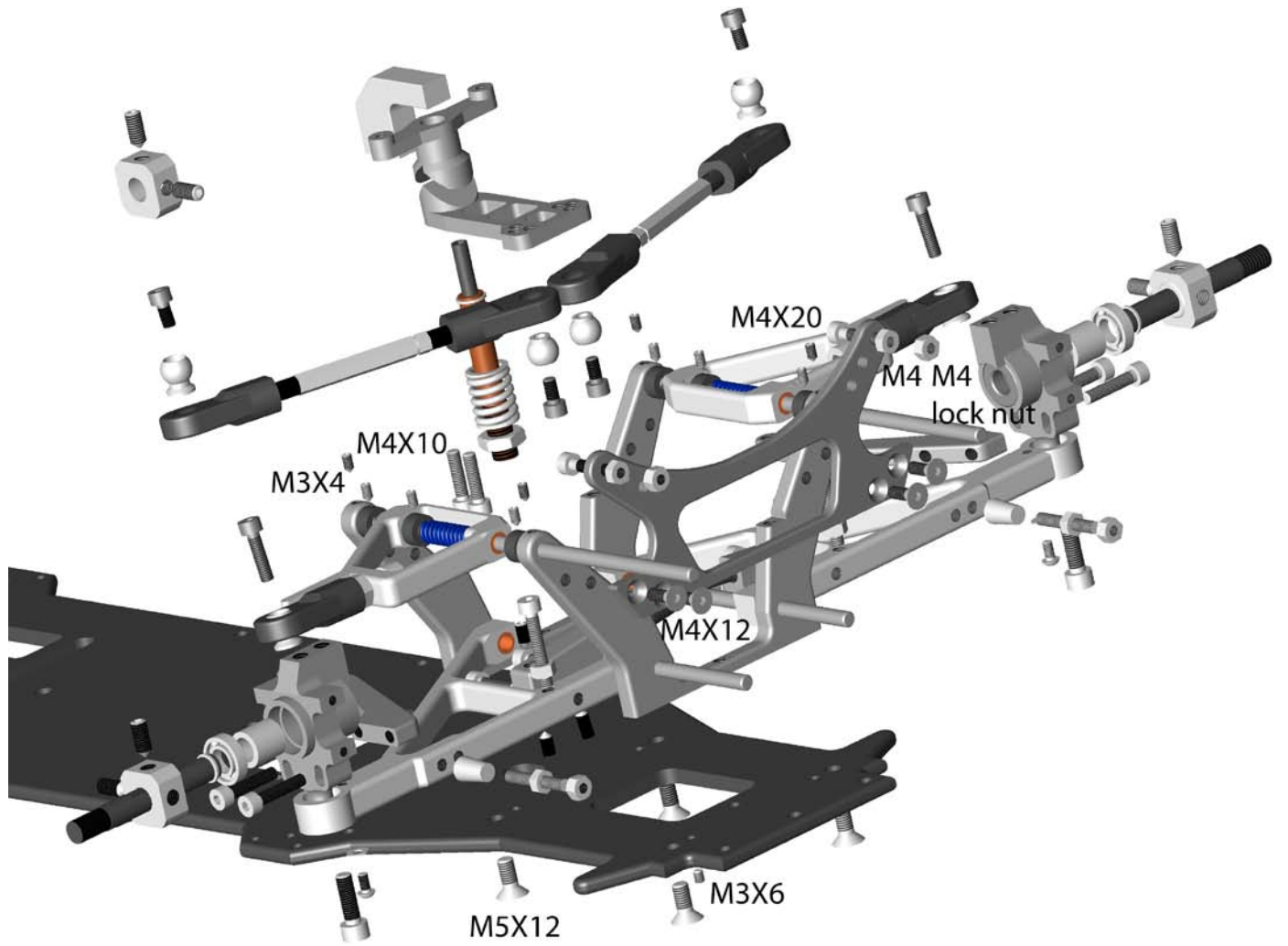

STEP 5 REAR AXLE AND BODY REAR SUPPORT

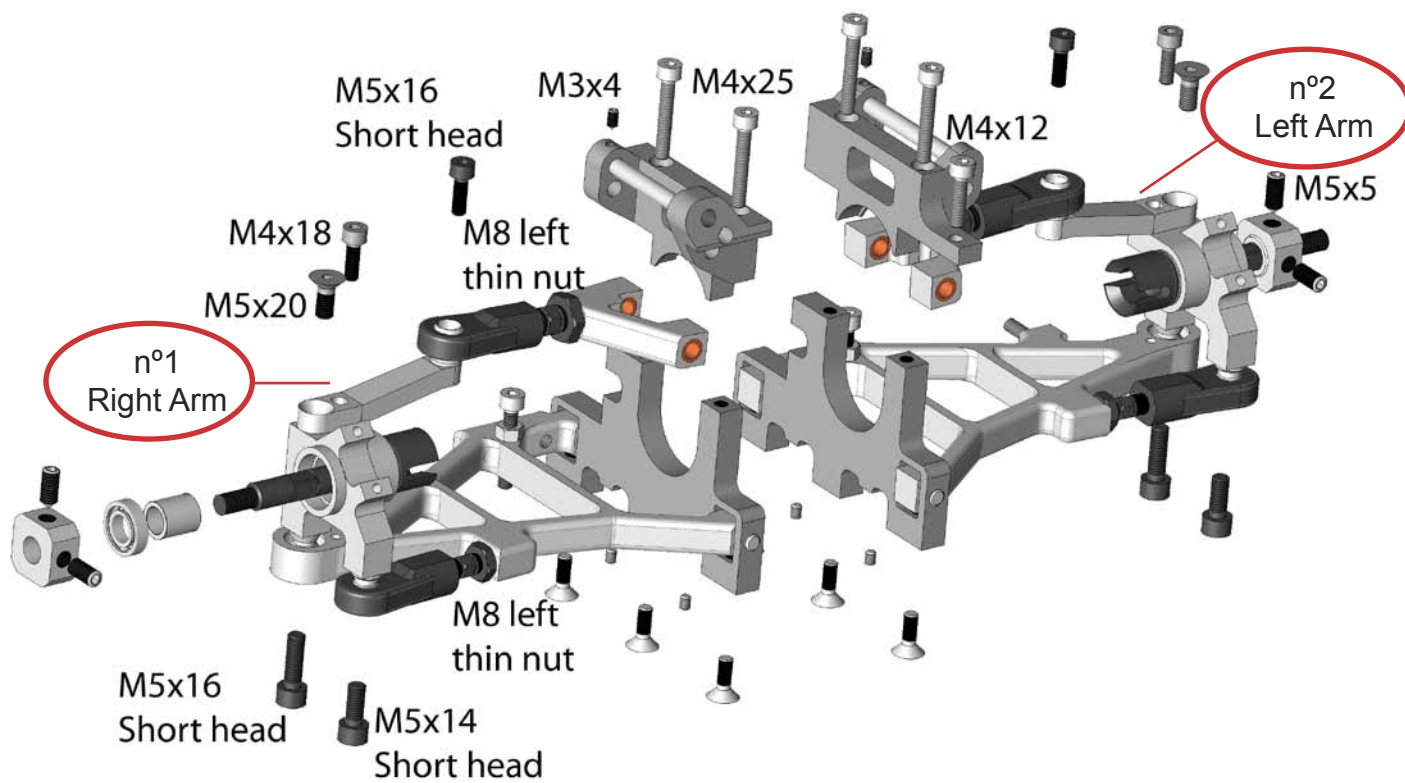
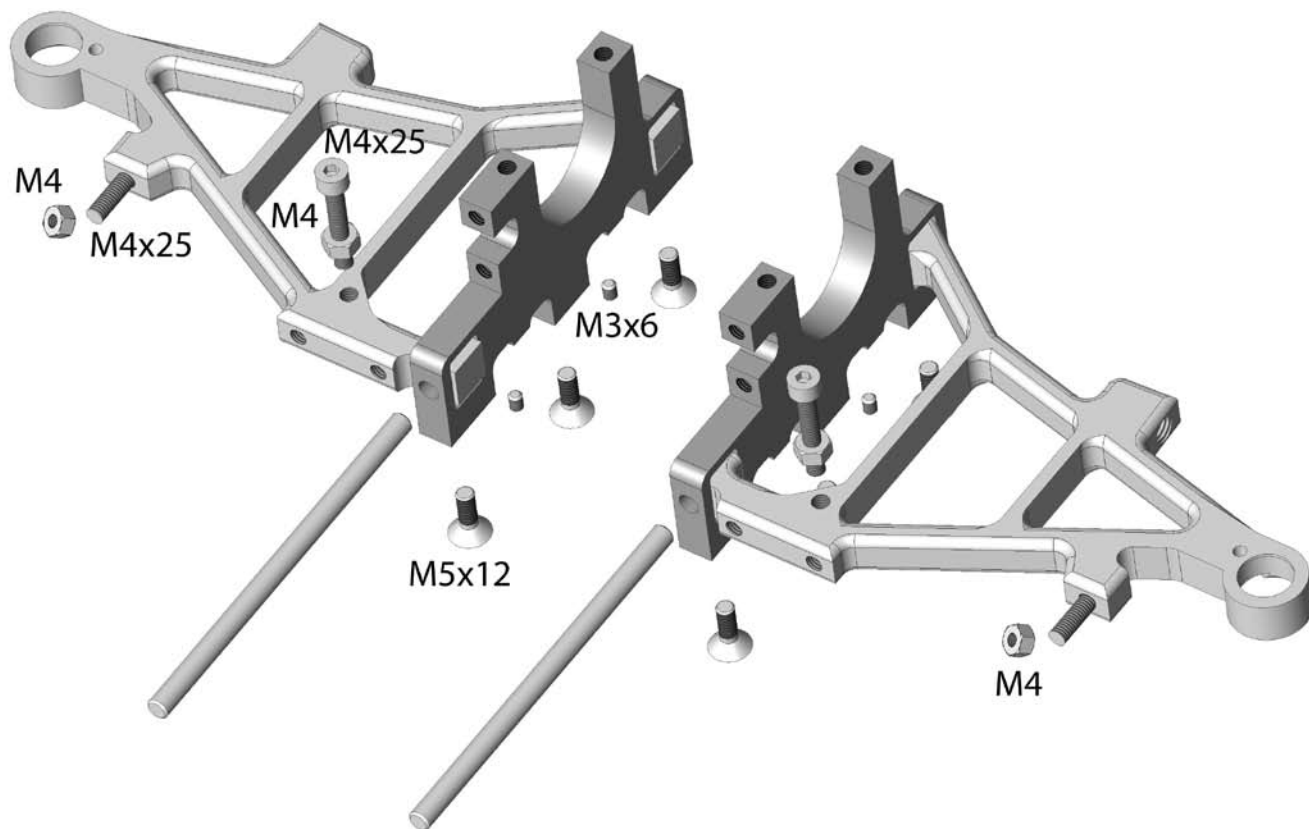

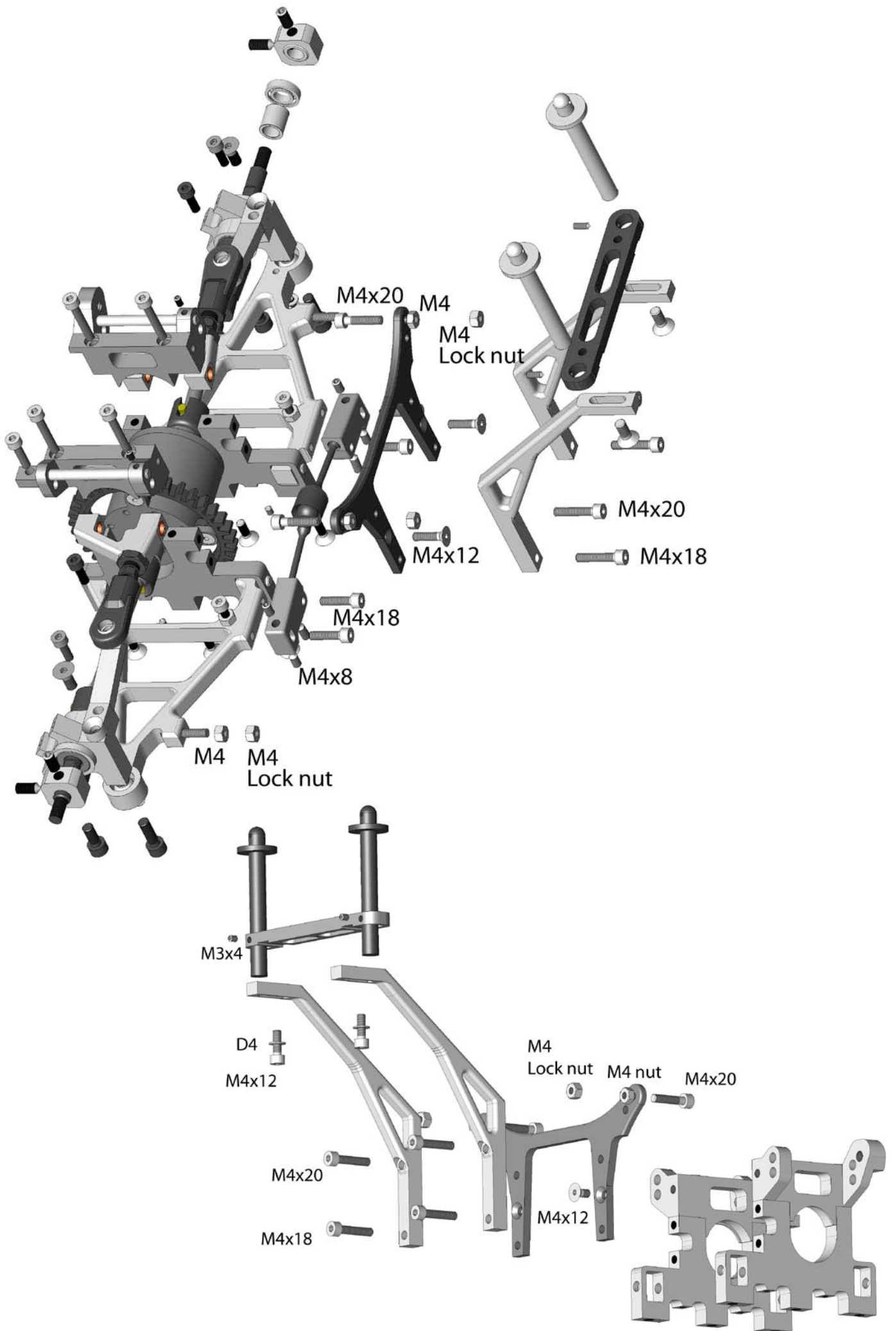

**STEP 6
DIFFERENTIAL**

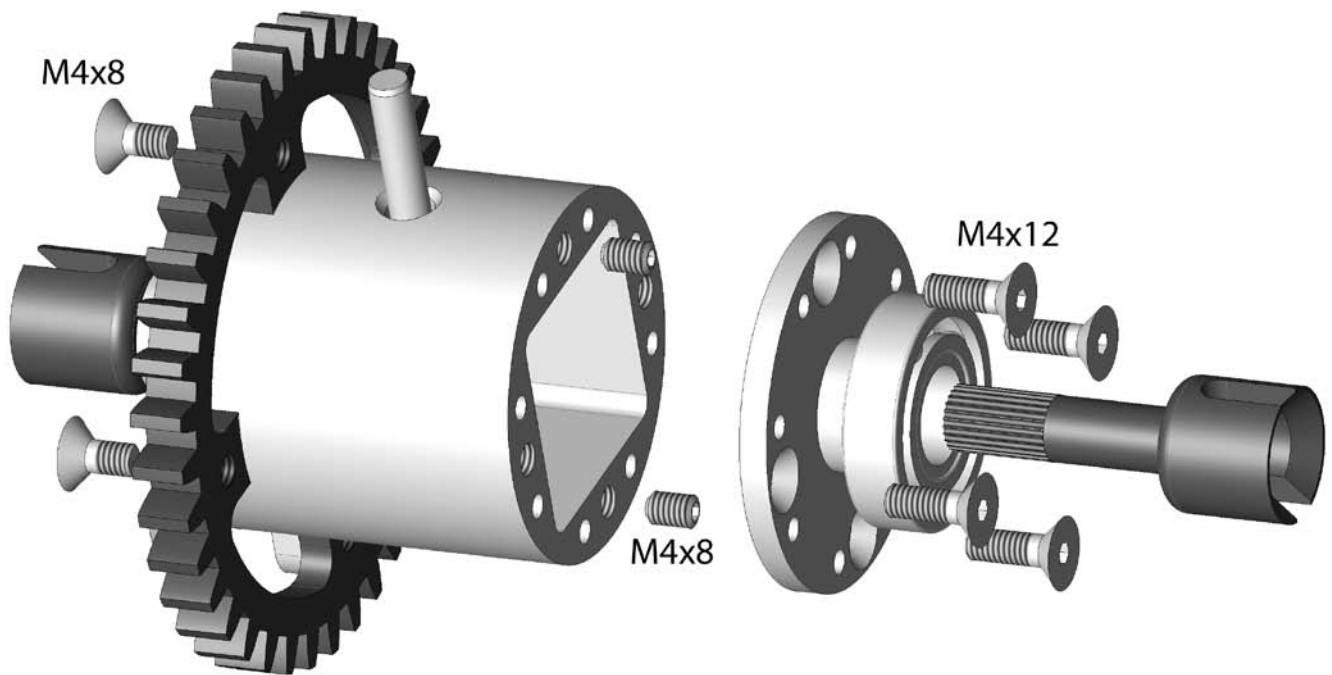

**STEP 7
ADJUSTABLE CLUTCH**

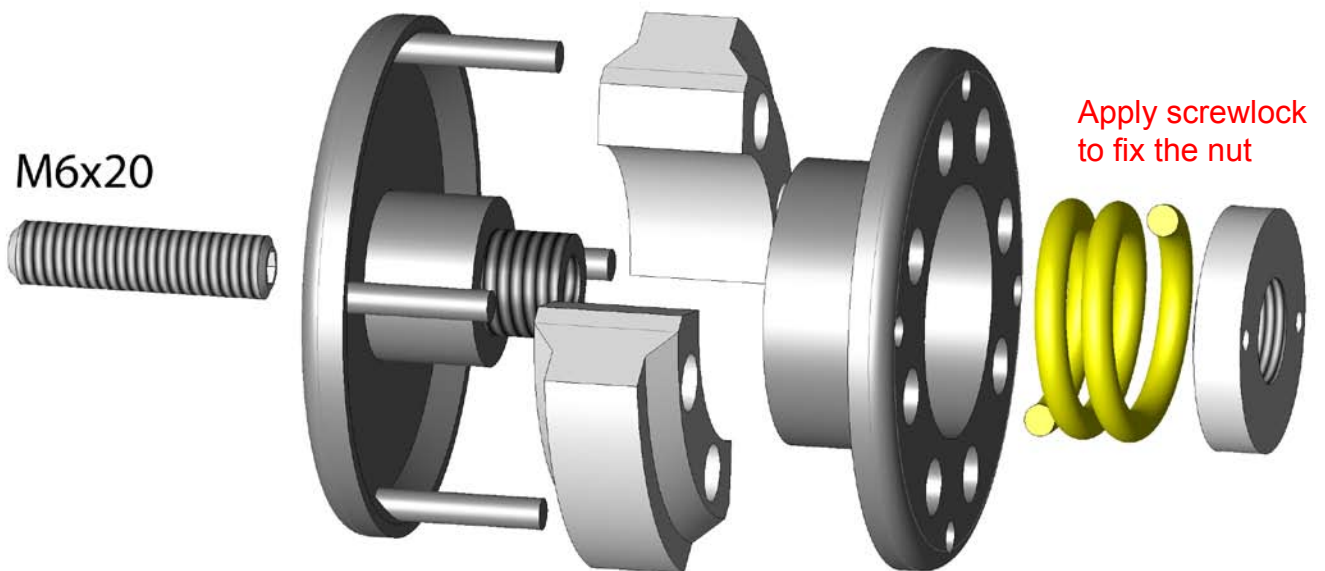

- | | |
|---|--------------|
| Set Black Power shoes (includes in the kit) | n° 150202/7 |
| Set Red Power shoes (optional part) | n° 150202/8 |
| Soft spring (includes in the kit) | n° 150202/55 |
| Hard spring (optional part) | n° 150202/66 |

**STEP 8
TRANSMISSION**

**FIX THE ENGINE with
5 screws M5x12**

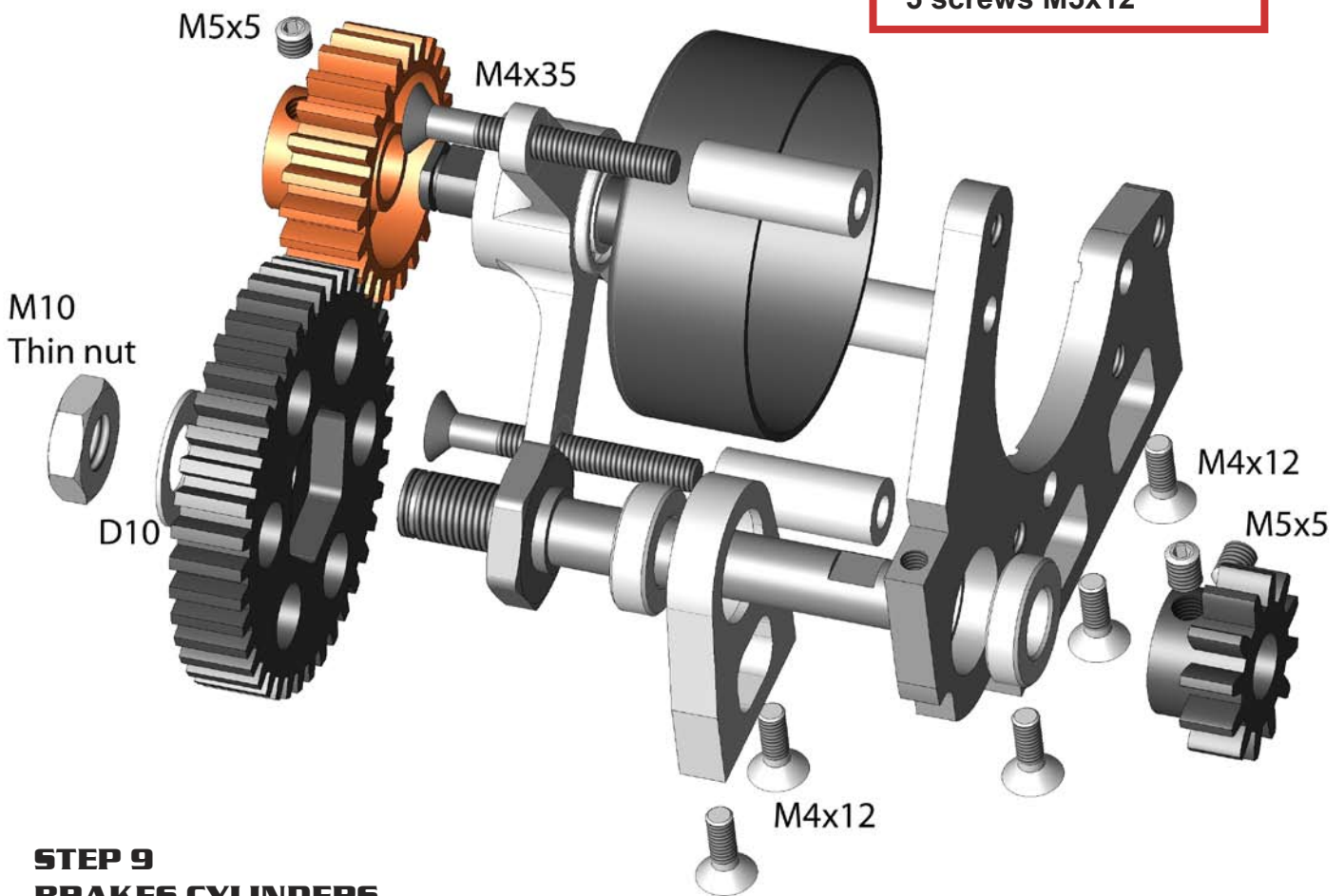

**STEP 9
BRAKES CYLINDERS**

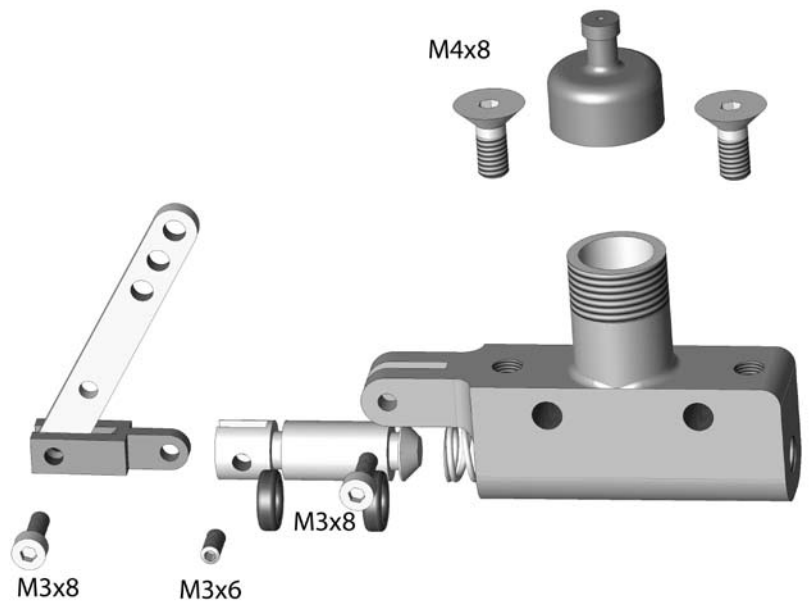
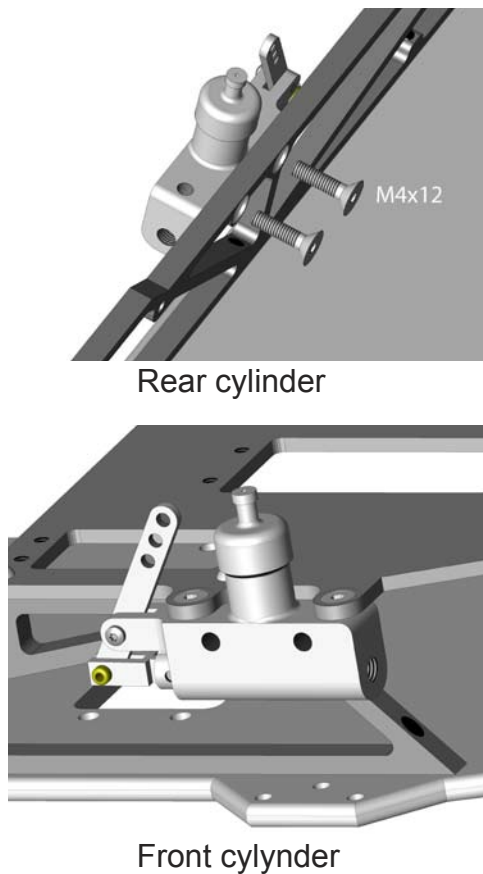

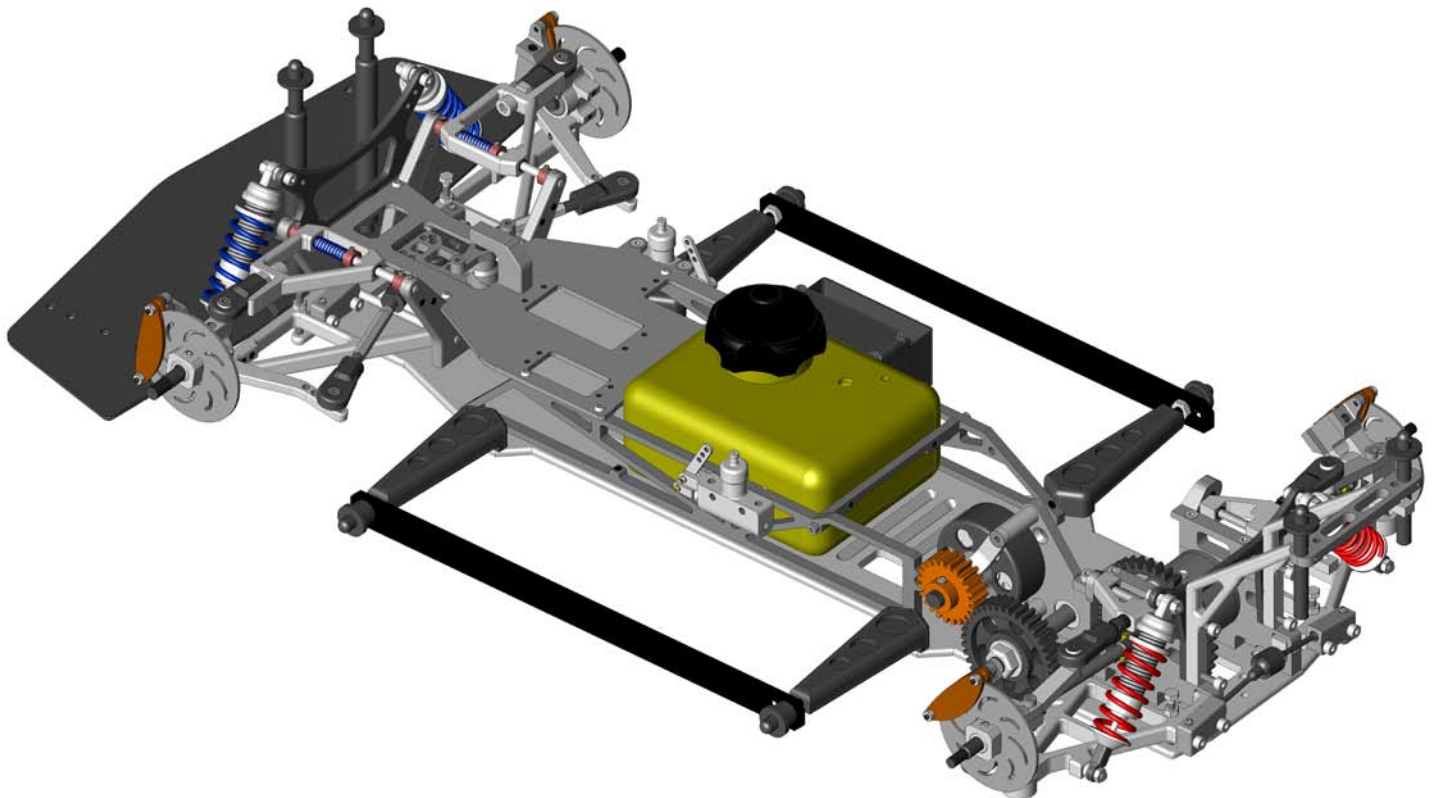
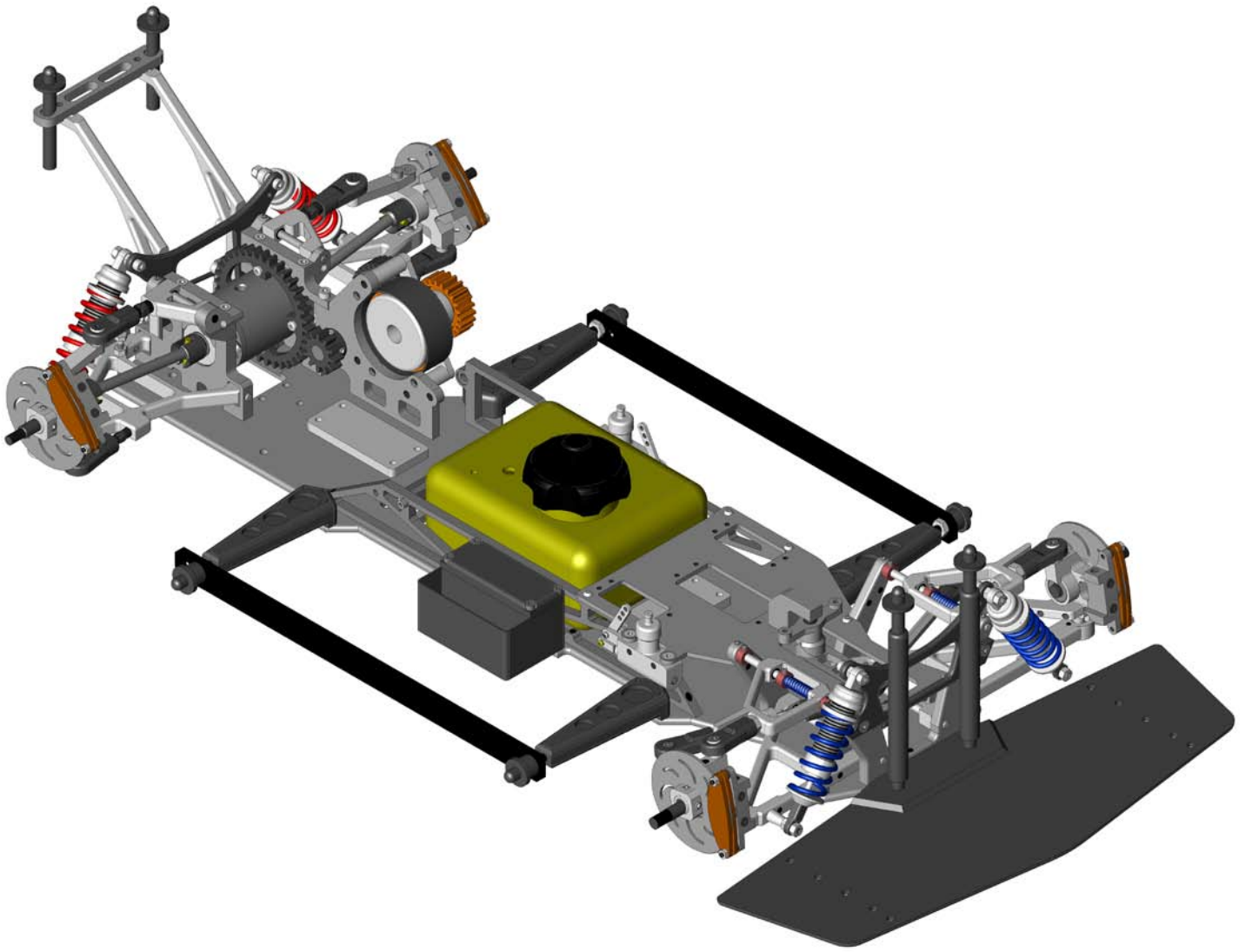

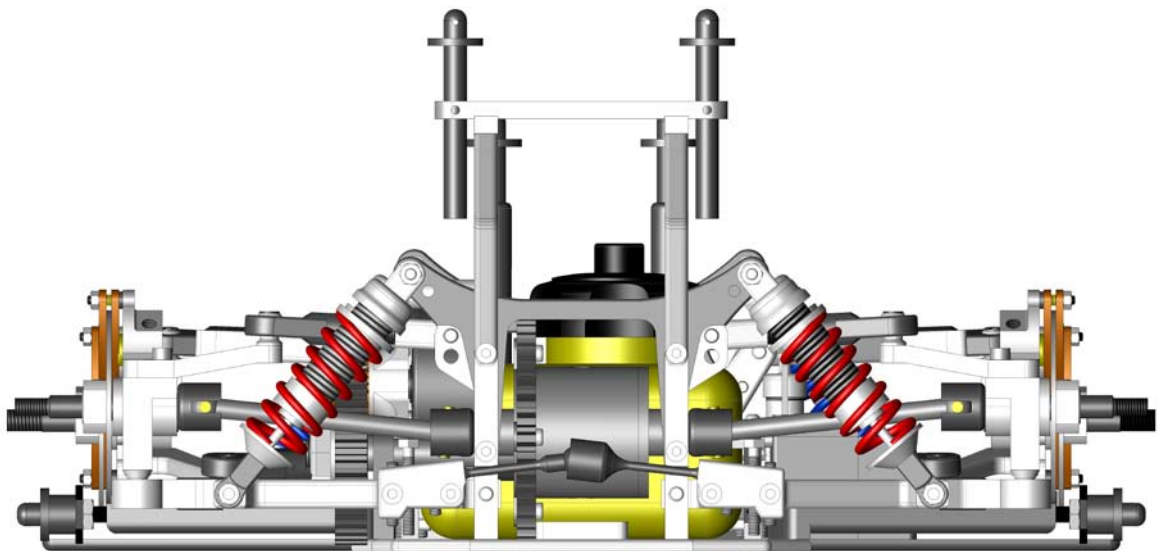
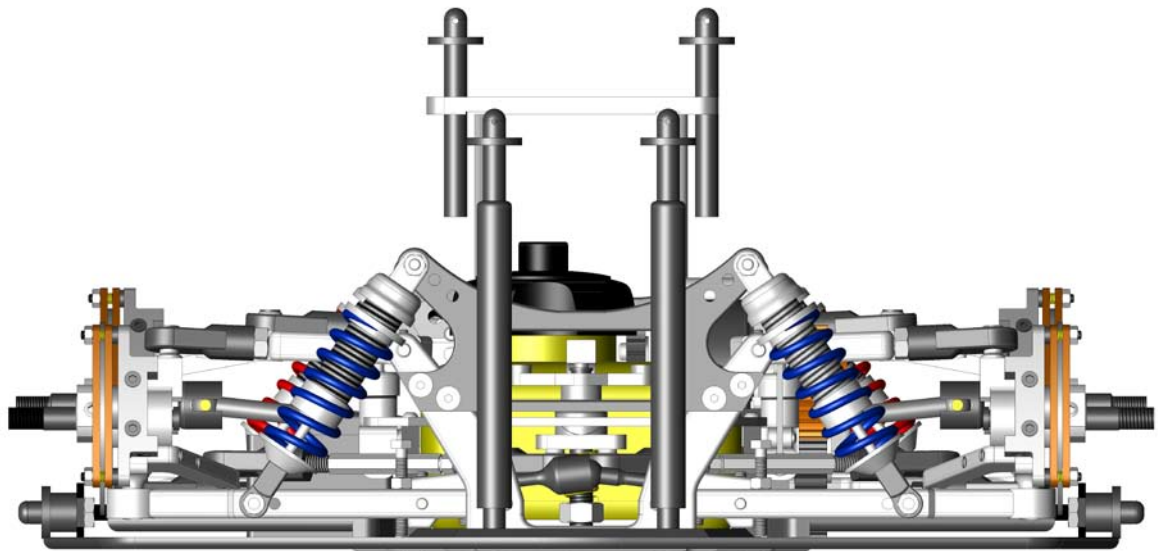
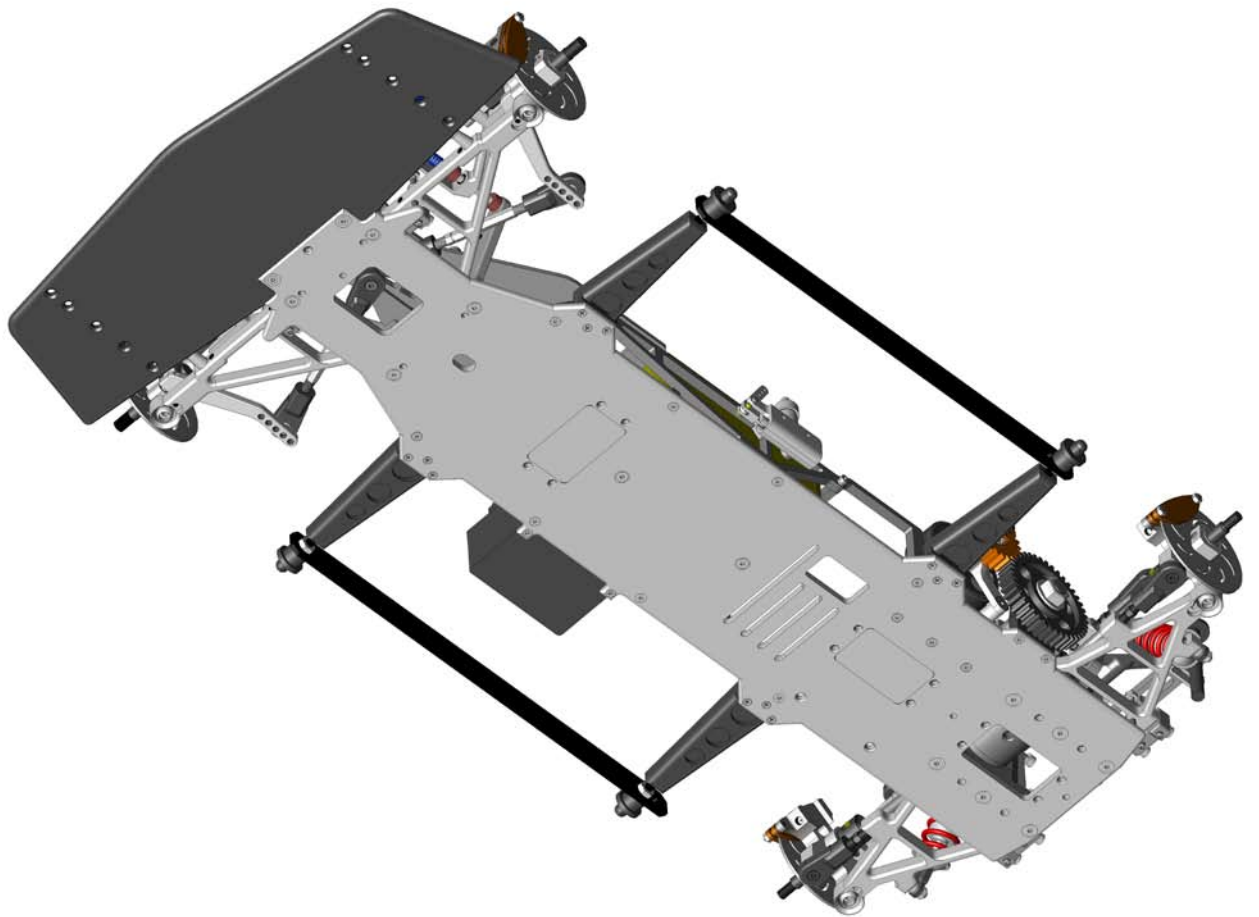

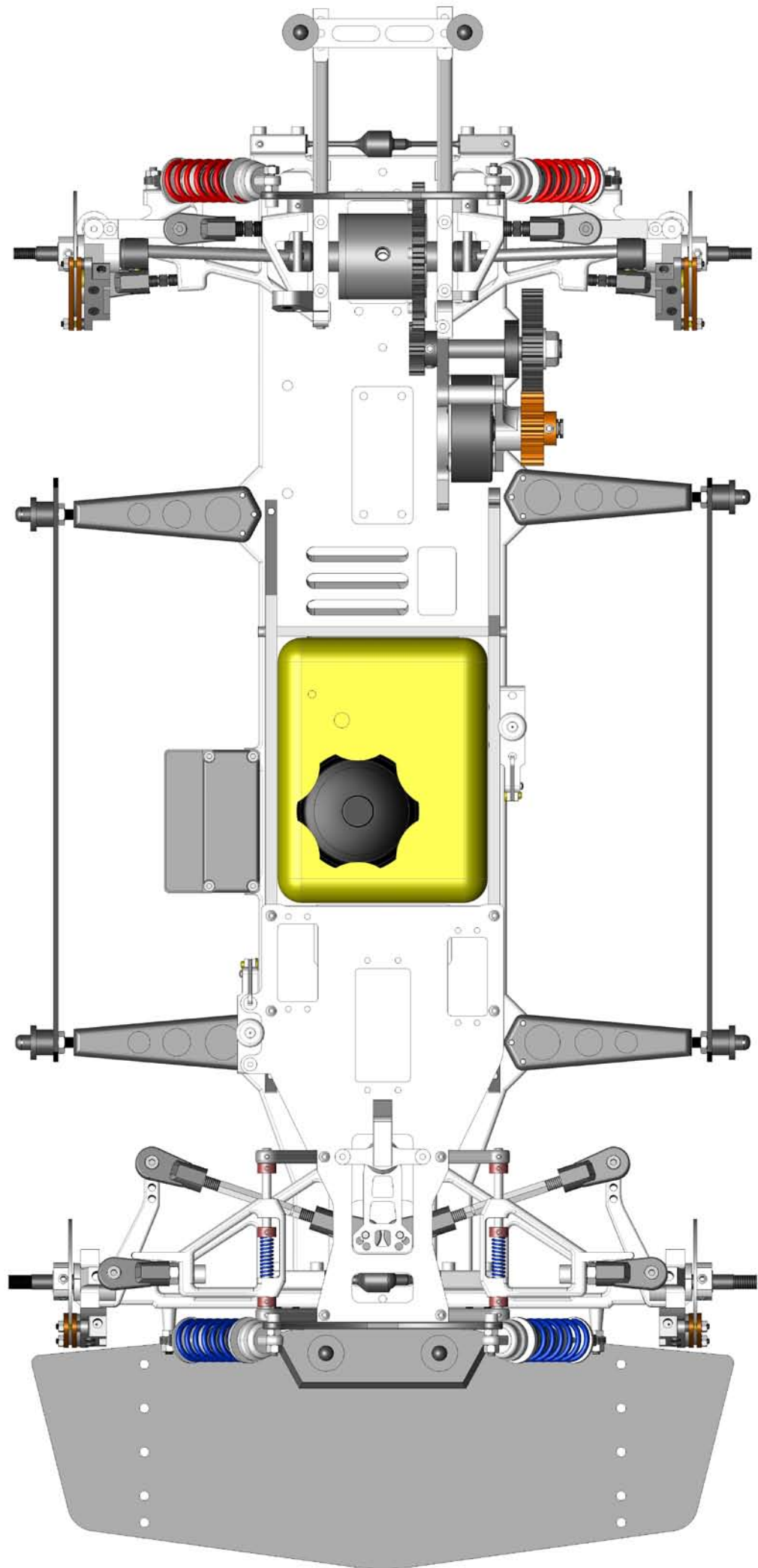

NUMBER PARTS LIST

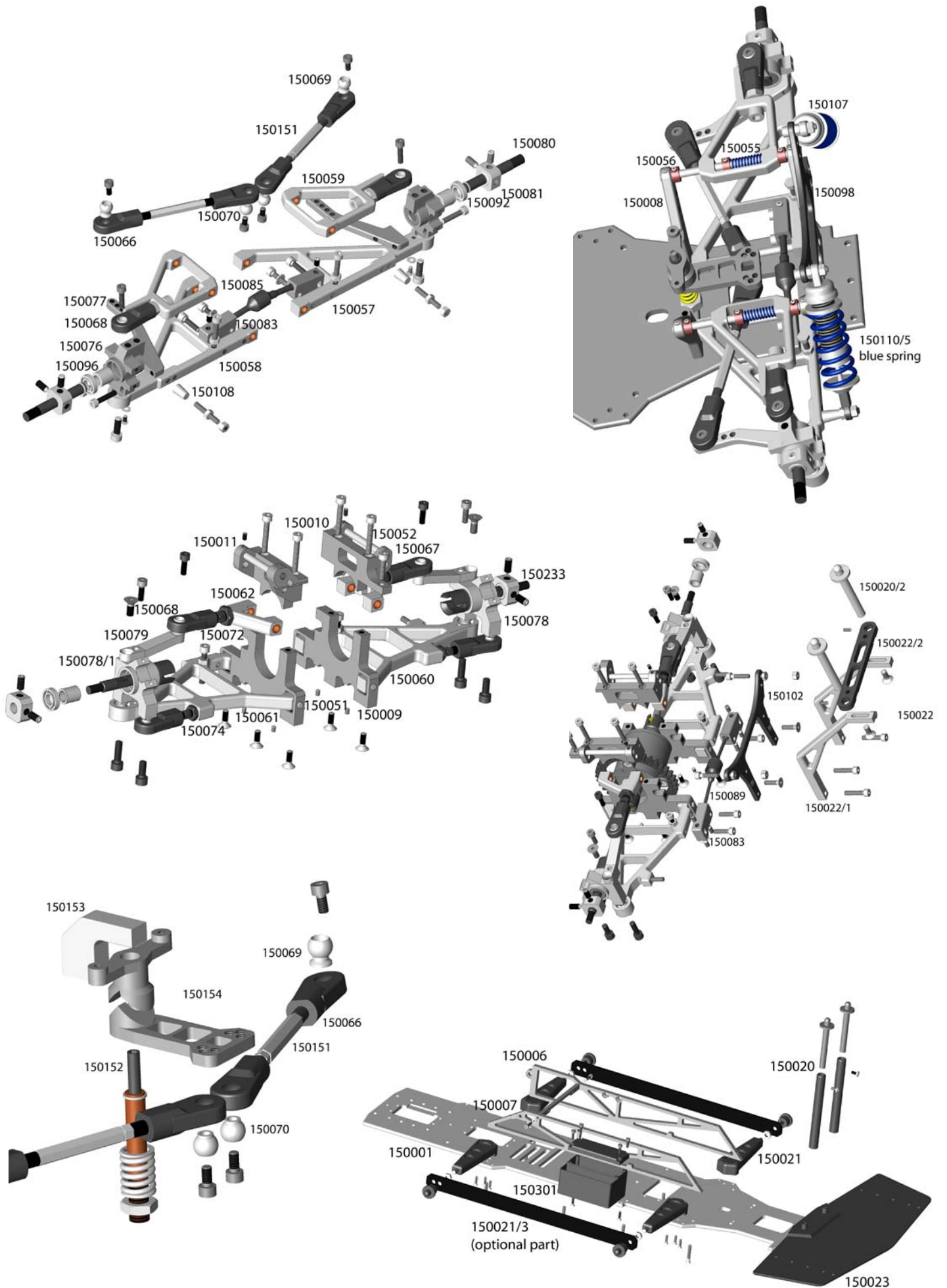

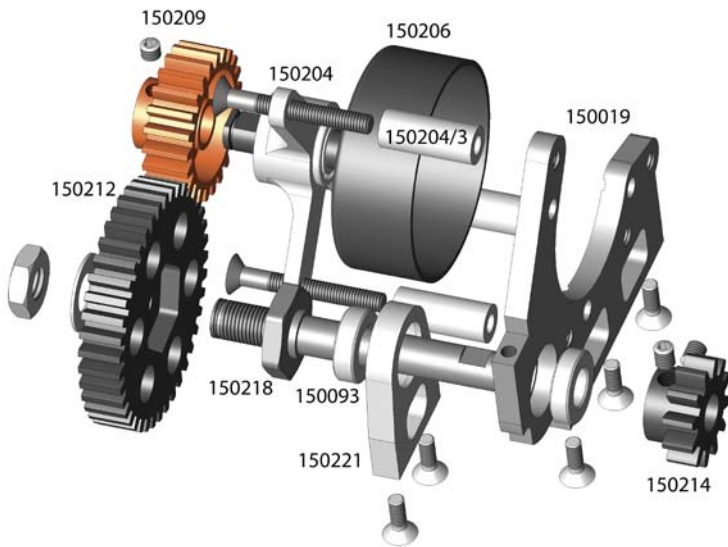

150202 Adjustable clutch

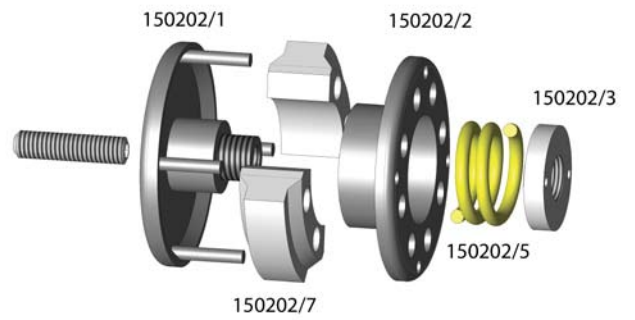

150222 Basic diferencial

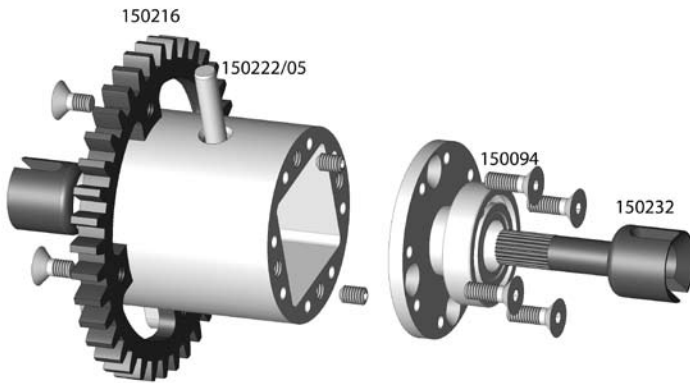

150260 Brakes main cylinder

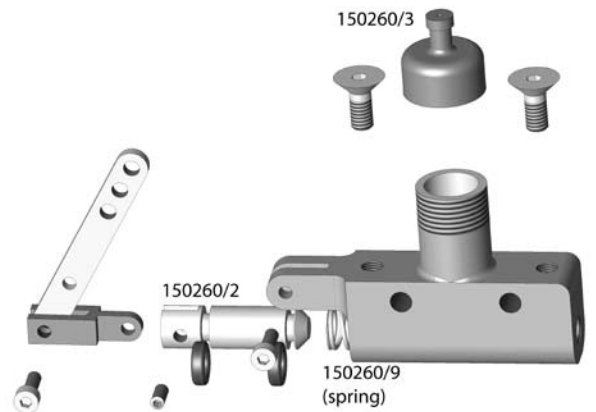

150267 Complete caliper brake

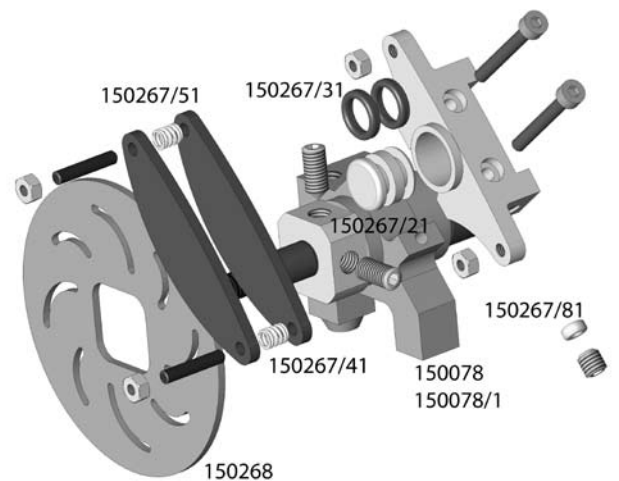
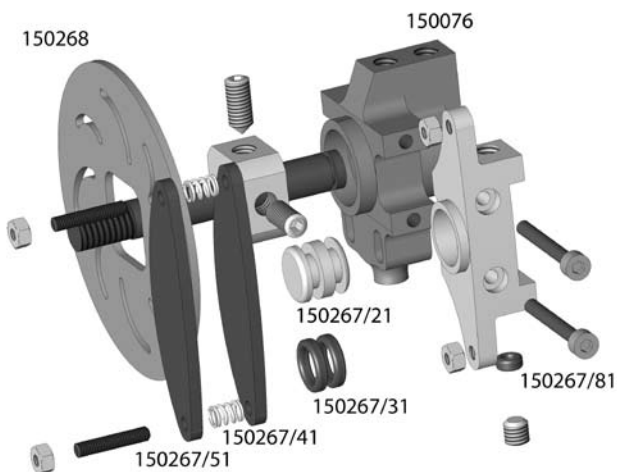

contrast
NEO 1R5

www.contrast-racing.com

Driver
 Date
 Track

Air temperature
 Track temperature
 Amb. conditions

test race championship clasification head subfinal final

Front axle

Oil

 Spring

Caster Right
 Caster Left
 Toe in (-)/out (+)
 Camber Right
 Camber Left
 Ground clearance maximum height

Rear axle

Oil

 Spring

Toe in
 Camber Left
 Camber Right
 Ground clearance maximum height

Roll bars

Rear roll bar
 Inclination High
 Medium
 Low
 Front roll bar
 High
 Medium
 Low

Weight

Total weight
 Front weight
 Central weight
 Rear weight

Transmition

Final ratio
 First gear
 Third gear
 Diff. gear
 Second gear

Tyres

Front Left
 Front Right
 Rear Left
 Rear Right

Results Final Position

Best lap time
 Mid lap time
 Driver opinion